

OXFORD

LAB PRODUCTS

Benchmate C6V Centrifuge



Visit www.oxfordlp.com to see the complete product offering and / or learn more about our products.

Call us at 800-554-4920 to schedule additional product demos or learn about the best consumables for your equipment.

TABLE OF CONTENTS

1. Introduction.....	1
2. Intended Use.....	1
3. Safety Precaution.....	1
4. Features.....	2
5. Technical Specification.....	3
6. Standard Accessories.....	3
7. Installation.....	4
8. Standard Parts Listing.....	6
9. Tube Holder & Adaptors.....	7
10. Rotor Installation.....	10
11. Balancing the Rotor.....	11
12. Operation.....	12
13. Troubleshooting.....	15
14. Warranty Statement.....	16
15. Product Disposal.....	17

1. INTRODUCTION

This manual provides important safety information for the Oxford Benchmate C6V centrifuge. It should be kept near the centrifuge for quick & easy reference. The C6V centrifuge is equipped with maintenance free brushless DC motor drive and a safety feature of imbalance detection. The centrifuge can be used for multiple application diagnostics & will work with variety of blood collection tubes.

2. INTENDED USE

The C6V centrifuge is designed for blood & other clinical applications like PRP, medical practitioners, pathological laboratories and hospitals.

3. SAFETY PRECAUTION

1. Never use the centrifuge in any manner not specified in the manual.
2. Never move the centrifuge while it's operating .
3. The rotor must always be securely fastened. If the centrifuge makes an unusual noise during the operation, the rotor fit needs to be checked.
4. The rotor must be loaded symmetrically.
5. Do not use the centrifuge or rotor, if it is not installed correctly or it is damaged.
6. Do not use the centrifuge or rotor if it shows any sign of external mechanical or electrical damages.
7. The centrifuge must be used only for the specified application. It must not be operated in hazardous or flammable environment & no hazardous or flammable content should be centrifuged.
8. Do not fill tubes while they are in the rotor. Liquid spillage may harm the device.

9. If liquid is spilled on the rotor or rotor chamber, the centrifuge must be cleaned immediately.
10. “Tube Holders” are a part of the Rotor. They should be placed in the rotor whether 2,3,4 or 6 tubes are being used.

4. FEATURES

- Maximum volume of 6x15ml
- Imbalance detector with auto cutoff for safe operation
- Brushless DC motor for maintenance free performance
- Lid lock safety-the lid opens automatically on run completion
- Digital display with speed and time indicator
- RPM setting from 500-6500 RPM with a count of 100
- One press changeover from RPM to RCF functionality
- Digital countdown Timer
- Reduction adaptors for tubes with volume less than 10 ml
- Emergency lid release during power failure
- Automatic internal diagnosis & error display
- Silent operation

5. TECHNICAL SPECIFICATION

Motor Type	Brushless DC Motor
Maximum Speed	6500 RPM
Run Time	1 to 30 minutes & infinite mode
Speed Setting	500 to 6500 RPM
Speed Accuracy	± 100 rpm
Maximum Volume	6x15 ml
Maximum RCF	3684 x g
Fix Angle	25°C
Acceleration Time	25 seconds
Deceleration Time	39 seconds
Size (L x B x H)	260 x 244 x 203 mm
Weight	4 Kg (with rotor)
Input Voltage	100-230 VAC, 50/60 Hz
Output Voltage	24 VDC
Power Consumption	100 W

6. STANDARD ACCESSORIES

1. Power supply adaptor
2. 6 - slots rotor (Pre-installed)
3. T-Allen Key
4. Reduction Adaptors (set of 6)
5. Tube Holder & Rubber cap (6 nos.)
6. Product user manual & warranty card

7. INSTALLATION

Gently remove the upper packaging and take out the centrifuge by holding it from the bottom. When the centrifuge is used for the first time, ensure that all the packaging and accessories are removed from the rotor chamber. The rotor is pre-installed. Please make sure that rotor is firmly tightened. Accessories and user manual are kept inside the box with the centrifuge. Please keep all the packaging in safe storage for at least 2 years for warranty purpose.

The following points are important for proper installation:

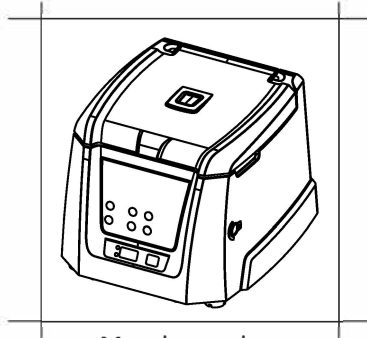

Must be used on
Flat & Non - Slippery
Surface

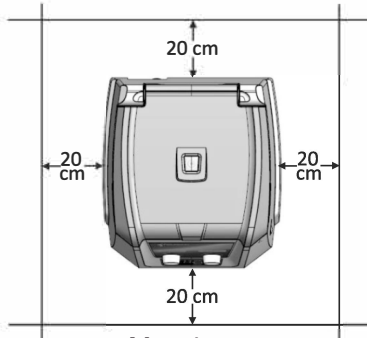

Must have
Clearance of 20 cm
from all 4 sides

7. INSTALLATION

7.1 Connecting Power Adaptor

1. Connect one side of power adaptor to rear side of centrifuge and other to supply as shown in the figure below.
2. Rotate clockwise the adaptor nut to tighten the adaptor with the centrifuge. Ensure the power switch is OFF while connecting the power adaptor.
3. The sticker on the body & jack are indicating the position of the rib on the jack. While fitting the adaptor to the unit-please match the sticker position as shown in the figure below & gently push it in.

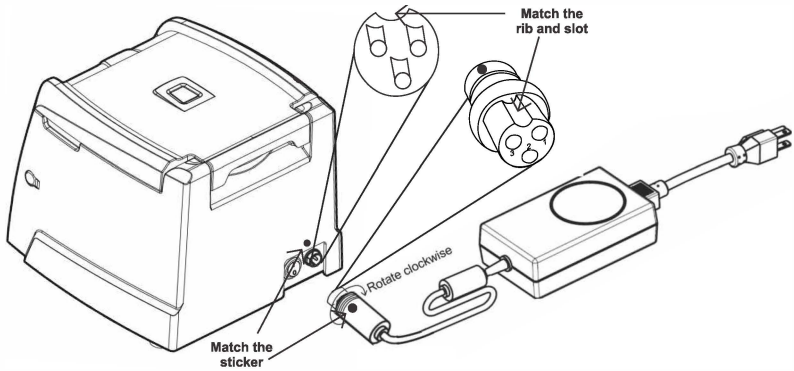

4. If matched correctly the plug will go in easily without much force (do not try to force the plug in if it is not matched properly). Once the plug is inserted into position, turn the loose upper ring clockwise to tighten & to secure the fitment.

8. STANDARD PARTS LISTING

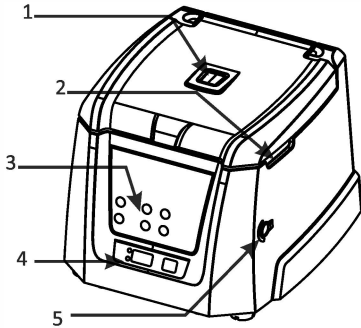

Front View

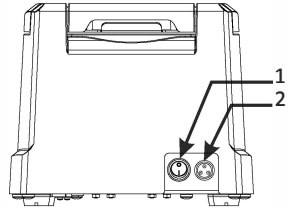

Rear View

1. View Window
2. Groove to open the lid
3. Operation and setting Buttons
4. Display
5. Emergency Lid Release

1. Power Switch
2. Adaptor Port

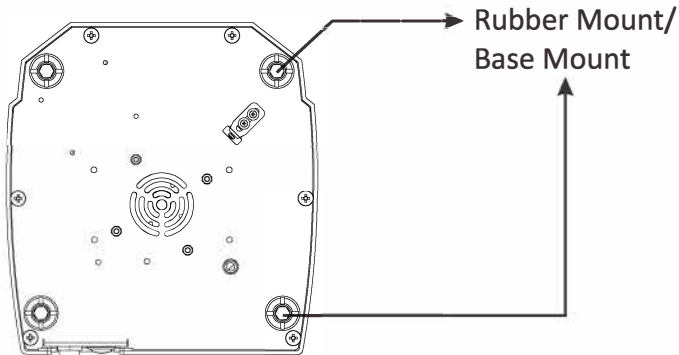

Bottom View

9. TUBE HOLDER & ADAPTORS

The C6V centrifuge features centrifugation for wide range of volumes from 1ml to 15ml with the combination of its adaptors. The accessories included are:

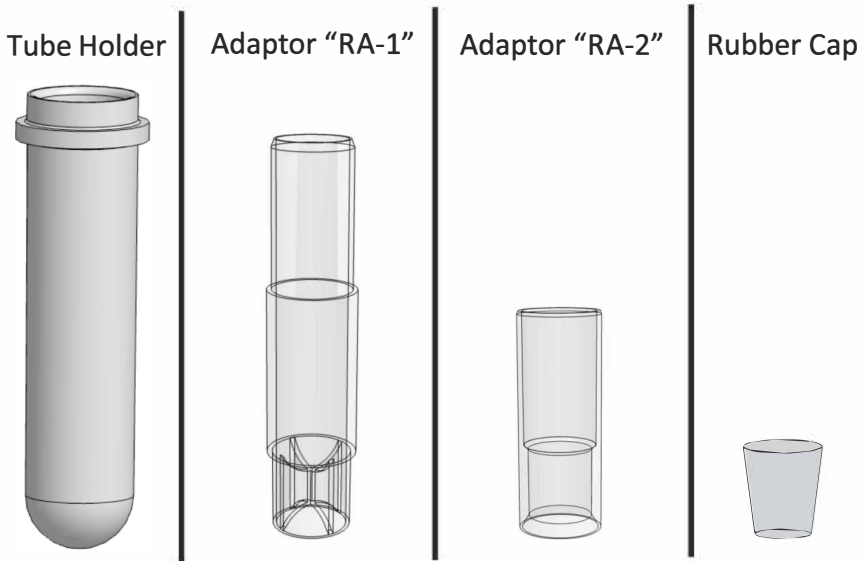

“Tube Holders” are always to be used with the rotor. All of the 6 “Tube Holders” are mandatory to be placed in the rotor whether 2,3,4 or 6 tubes are used in balanced condition. By combining the above two adaptors and rubber caps, three different reduced adaptor can be designed to hold different types of blood collection tubes. The different adaptor combinations along with tube holder, for different blood collection tubes are illustrated on pages 7 and 8.

Note: 1) Maximum RCF value changes for different length of tubes. 2) “Tube Holders” are the part of Rotor. All 6 “Tube Holders” are mandatory to place whether 2,3,4 or 6 tubes are used in balanced condition.

9. TUBE HOLDER & ADAPTORS

COMBINATION A:

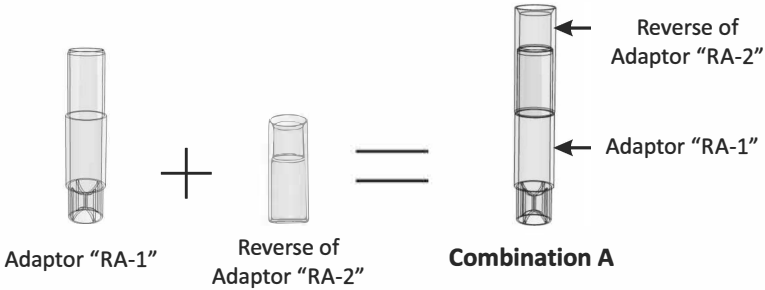

COMBINATION B:

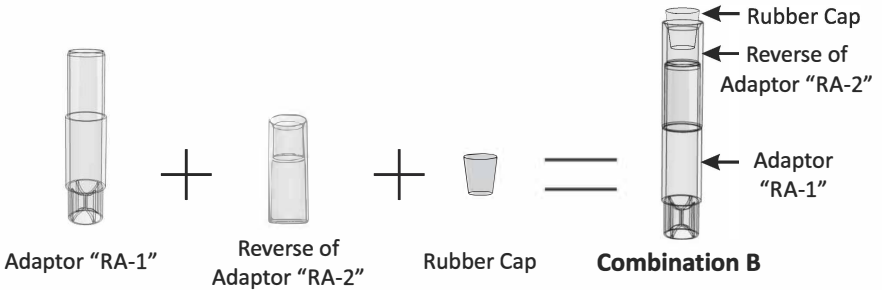

COMBINATION C:

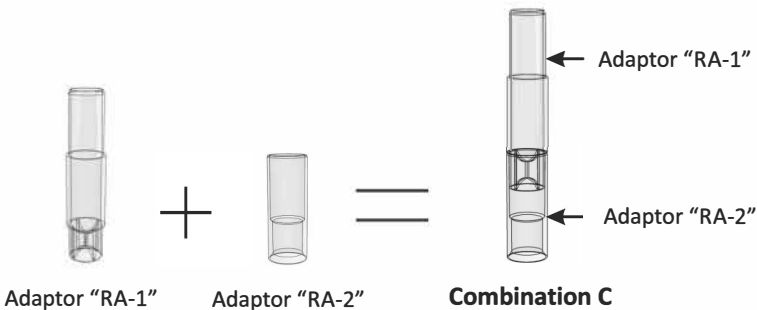

9. TUBE HOLDER & ADAPTORS

ADAPTOR COMBINATION & TUBE SIZES

1) NO ADAPTOR COMBINATION

The maximum diameter and proposed length for such combination are:

Maximum Tube Diameter : 18 mm

Proposed Tube Length : 90 to 120 mm



TUBE HOLDER

2) COMBINATION "A" :

The maximum diameter and proposed length for such combination are:

Maximum Tube diameter : 13 mm

Proposed Tube Length : 75 to 100 mm



A

3) COMBINATION "B" OR "C" :

The maximum diameter and proposed length for such combination are:

Maximum Tube Diameter : 13 mm

Proposed Tube Length : 55 to 75 mm

Check both the criteria (Max. Diameter & Proposed Length) of the blood collection tubes and use the appropriate adaptor-tube holder combination or only tube holder to accommodate the tubes.

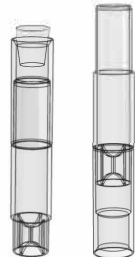

B

C

10. ROTOR INSTALLATION

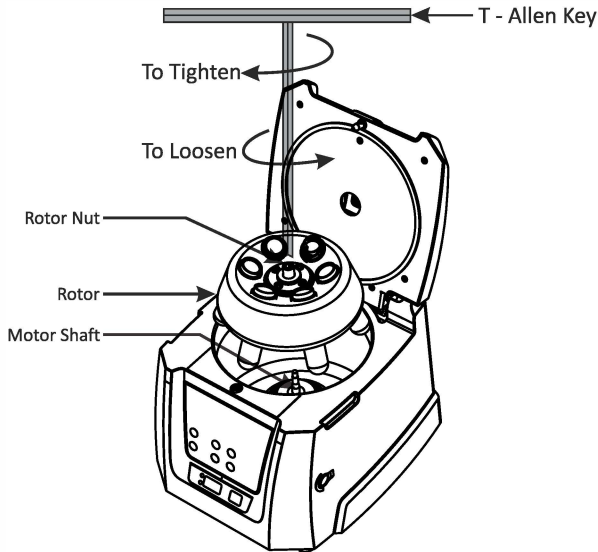

The rotor of the centrifuge is pre-installed. In case of any spillage, remove the rotor as shown in the above figure to clean the rotor and its chamber thoroughly.

10.1 REMOVING ROTOR

1. To remove rotor, first remove the Tube Holders.
2. Using T-Allen key, loosen the rotor nut by rotating rotor nut counter clockwise and take the out rotor vertically

10.2 INSTALLING THE ROTOR

1. Make sure the rotor shaft and the rotor mounting hole are clean. Load the rotor vertically into the motor shaft.
2. Put the T-Allen key in the rotor nut & turn clockwise to tighten the rotor.
3. After properly fastening the rotor, place the Tube Holders into the rotor.

11. BALANCING THE ROTOR

1. Always balance the rotor before centrifugation. Symmetrical loading of tubes in the rotor is necessary. Otherwise vibration or imbalance can occur which can cause serious damage to the centrifuge. The following are process of symmetrical loading of centrifuge tubes inside the rotor.

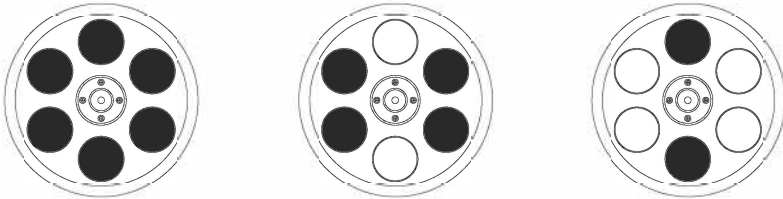

2. The samples in the tubes should be of equal volume. To achieve a balanced condition of the 6 "Tube Holders are mandatory to place inside the rotor whether 2, 3, 4 or 6 tubes are being used
3. If the tubes are not loaded symmetrically then the imbalance detector will cut off the running centrifuge for safety reasons. This will stop the centrifuge and Err 55 will be seen indicating the tubes are not loaded symmetrically. To resume operation, load the tubes symmetrically & restart the centrifuge.
4. Below are examples of incorrect method of loading tubes into the centrifuge rotor.

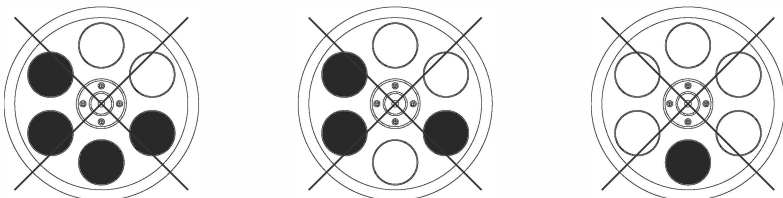

12. OPERATION

After properly installing the centrifuge, switch ON the centrifuge from the rear side by pressing the power switch. The lid status will be seen in the display. If the lid is open, the display will show “Lid” and if it is closed, the set RPM will be displayed. Please ensure that the Tube Holders are inside the rotor.

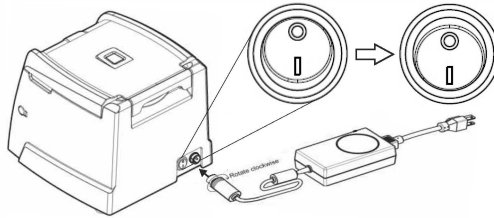

12.1 SETTING THE SPEED AND TIME

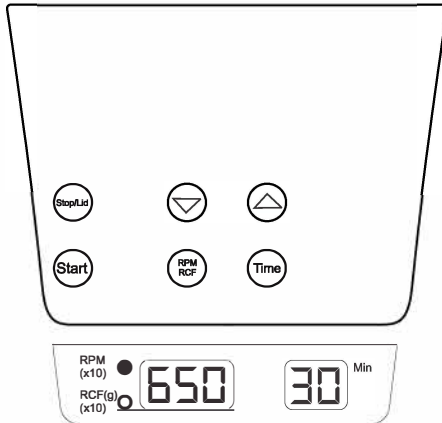

1. To set the speed press the RPM/RCF button first, then with the use of increment & decrement buttons to set the desired speed.
2. The increase and decrease of speed will take place in the steps of 10 RPM. The Display window at the bottom will show the values.
3. The minimum and maximum speed of the centrifuge is 500

RPM and 6500 RPM respectively. Speed is to be read as value x 10 in the display window.

4. The speed can be changed during the operation of the centrifuge, upon changing the speed, centrifuge will start running on the updated speed for the remaining time left on the centrifuge cycle.

Note: Centrifuge will not run with the lid open.

12. OPERATION

5. To set time press the TIME button first, then use INCREMENT and DECREMENT buttons time can be set as desired time. The set time will be displayed in the display window at the bottom.
6. The timer of the centrifuge allows you to choose between 1 minute to 30 minutes, thereafter it goes in the infinity mode displayed as ∞
7. The centrifuge incorporates a count down timer, after each minute of operation the value of the timer is reduced by 1 minute.

12.2 SWITCHING TO RCF DISPLAY

Press the RPM/RCF to change the mode from RPM to RCF, while in RCF mode the speed value is to be read as value x 10 in the display window. The maximum RCF of the centrifuge is 3684xg. Press the RPM/PCF to see corresponding RCF value.

12.3 START & STOP OPERATION

Once all the parameters like Speed & Time are set, press the "Start" button to START operation.

1. Make sure that the lid is closed before starting the centrifuge.
2. The display will keep on blinking until the set parameters are. (RPM/RCF & Time) reached. Once the set parameters are reached, the display will blink multiple times till the set value would reach.
3. When centrifugation is completed the lid of the centrifuge opens automatically and the timer value will again start blinking.
Press the STOP/LID button any time the centrifuge needs to be stopped.
After every run the lid opens by itself, In any other case, when the lid needs to be opened push the STOP/LID button to open the lid.

12. OPERATION

12.4 OPENING THE CENTRIFUGE LID IN CASE OF POWER FAILURE

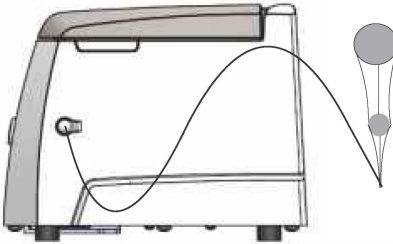

Disconnect the centrifuge from the main supply. Wait until the rotor comes to a standstill (this may take some time). Once the rotor has stopped, pull out the emergency lid release as

shown in the figure. This will open the centrifuge lid. After the centrifuge lid opens, push the thread back in the hole with your hand and fit the emergency release cap back in the hole.

12.5 IMBALANCE DETECTION

C6V centrifuge is equipped with an imbalance detection safety feature. When the rotor is not loaded symmetrically, imbalance detector gets activated. This will cut off the centrifugation & error “Err55” will be shown on the display. To correct the imbalance, open the centrifuge lid and correct the imbalance load using methods described in the balancing the rotor section (page no.11) of this manual. After correctly loading the tubes into the rotor turn off the centrifuge & turn it back on.

13. TROUBLESHOOTING

This centrifuge has a self – diagnostic function. If a problem occurs, an error/warning code will be displayed on the display screen and the operator can determine the malfunction with the warning code below.

ERROR	PROBLEM	SOLUTION
No display	No main power connection.	Check power & properly plugin power adaptor at both ends.
	Power failure	Check the main fuse of the lab.
	Improper connection.	Connect adaptor properly.
Err 55	Rotor not loaded symmetrically.	Load the rotor symmetrically & restart the centrifuge.
Centrifuge lid cannot be opened	Rotor is still spinning.	Wait for the rotor to come to a stop.
	Power failure	Press emergency lid release after rotor stops
Centrifuge shakes during acceleration & makes loud running noises while running	Rotor is not loaded symmetrically.	Load rotor symmetrically & restart operation
	Either a broken tube, damage to the rotor or motor is the cause for run noise.	Replace broken tube. For damaged rotor/motor contact a service representative.
	Rotor is damaged.	Remove & change rotor
Err 52	Rotor is Stuck	Turn OFF the centrifuge, Check & fit the rotor properly & turn ON the centrifuge

IMPORTANT NOTE:

1. *If the centrifuge is working slow or hot due to overdraw current, restart the centrifuge and check it again.*
2. *Do not use liquid with density higher than 1.2g/ml for full load operation.*

14. WARRANTY STATEMENT

This products is warranted to be free from defects in material and workmanship for a period of two (2) years from date of purchase. Your product will be duly repaired upon prompt notification in compliance with the following conditions :

- This warranty is valid only if the product is used for its intended purpose and within the guidelines specified in this instruction manual. This warranty does not cover damage caused by accident, neglect, misuse, improper service, natural forces, or other causes not arising from defects in the original material or workmanship. This warranty does not cover any incidental or consequential damages, commercial loss or any other damages from the use of this product.
- Any post manufacturing modification automatically terminates the warranty. The manufacturer is not liable or responsible for the product or its performance once it has been modified. The customer is be responsible for the product or use of products as well as any supervision required for safety. If requested, the products must be returned to the distributor in well packed and insured manner and all shipping charges must be paid.

Note: *Some states do not allow limitation on the length of implied warranties or the exclusion or limitation of incidental or consequential damages. This warranty gives you specific legal rights. This warranty is given expressly in lieu of all other warranties, expressed or implied.*

The purchaser agrees that there is no warranty of merchantability or of fitness for any intended purpose and that there are no other remedies or warranties, expressed or implied, which extend beyond the description on the face of the agreement. This warranty is only applicable to the original purchaser.

14. WARRANTY STATEMENT

Products received without proper authorization will not be processed for service. All items returned for service should be sent postage prepaid in the original packaging or other suitable packaging, padded to avoid damage. The manufacturer will not be responsible for damage incurred by improper packaging.

Note: *This warranty is valid only if the warranty is registered with the supplier within 30 days from the date of purchase.*

15. PRODUCT DISPOSAL



By observing proper disposal of the equipment, you will help conserve natural and environmental resources along with protecting human health.

This equipment is marked with the crossed out wheeled bin symbol to indicate that this equipment must not be disposed of with unsorted waste.

User is responsible for correctly disposing of the equipment by handing it over to an authorized facility for separate collection and recycling. Also, it's your responsibility to decontaminate the equipment in case of biological, chemical and/or radiological contamination, so as to protect from health hazards the persons involved in the disposal and recycling of the equipment.

Please contact your local dealer from whom you originally purchased this equipment to get more information about where you can drop off your waste equipment.

OXFORD

The logo for Oxford Lab Products features the word "OXFORD" in a bold, sans-serif font. The letter "O" is replaced by a stylized water droplet icon. Below "OXFORD" is the text "LAB PRODUCTS" in a smaller, bold, sans-serif font.

LAB PRODUCTS

Visit www.oxfordlp.com to see the complete product offering and learn more about our products.

Call us at 800-554-4920 to schedule additional product demos or learn about the best consumables for your equipment.

Send warranty card information to:

Oxford Lab Products
10360 Sorrento Valley Road
San Diego, CA 92121

Thank You for choosing Oxford Lab Products for your research.